



# STC03DE170

## HYBRID EMITTER SWITCHED BIPOLAR TRANSISTOR ESBT™ 1700 V - 3 A - 0.55 Ω

**Table 1: General Features**

$V_{CS(ON)}$	$I_C$	$R_{CS(ON)}$
1 V	1.8 A	0.55 Ω

- LOW EQUIVALENT ON RESISTANCE
- VERY FAST-SWITCH, UP TO 150 kHz
- SQUARED RBSOA, UP TO 1700 V
- VERY LOW  $C_{ISS}$  DRIVEN BY  $R_G = 4.7 \Omega$

### APPLICATION

- AUX SMPS FOR THREE PHASE MAINS

### DESCRIPTION

The STC03DE170 is manufactured in a hybrid structure, using dedicated high voltage Bipolar and low voltage MOSFET technologies, aimed to providing the best performance in ESBT topology. The STC03DE170 is designed for use in aux flyback smps for any three phase application.

**Figure 1: Package**

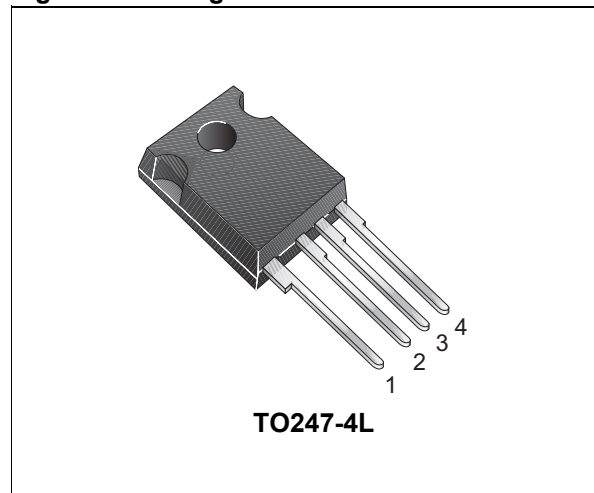

**Figure 2: Internal Schematic Diagram**

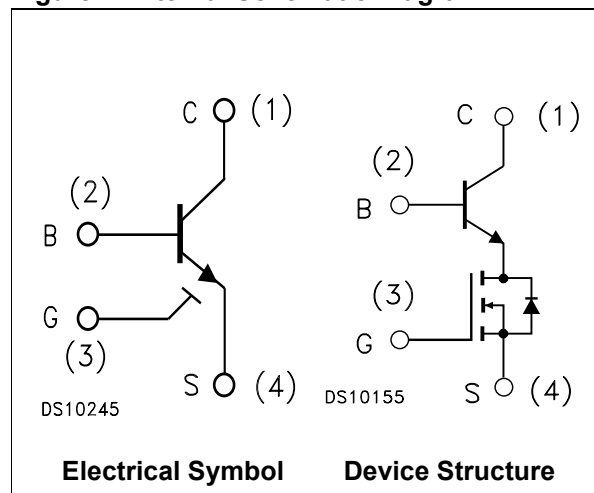

**Table 2: Order Code**

Part Number	Marking	Package	Packaging
STC03DE170	STC03DE170	TO247-4L	TUBE

**Table 3: Absolute Maximum Ratings**

Symbol	Parameter	Value	Unit
$V_{CS(SS)}$	Collector-Source Voltage ( $V_{BS} = V_{GS} = 0\text{ V}$ )	1700	V
$V_{BS(OS)}$	Base-Source Voltage ( $I_C = 0, V_{GS} = 0\text{ V}$ )	30	V
$V_{SB(OS)}$	Source-Base Voltage ( $I_C = 0, V_{GS} = 0\text{ V}$ )	9	V
$V_{GS}$	Gate-Source Voltage	$\pm 20$	V
$I_C$	Collector Current	3	A
$I_{CM}$	Collector Peak Current ( $t_p < 5\text{ ms}$ )	6	A
$I_B$	Base Current	2	A
$I_{BM}$	Base Peak Current ( $t_p < 1\text{ ms}$ )	4	A
$P_{tot}$	Total Dissipation at $T_C = 25\text{ °C}$	100	W
$T_{stg}$	Storage Temperature	-65 to 125	°C
$T_J$	Max. Operating Junction Temperature	125	°C

**Table 4: Thermal Data**

Symbol	Parameter	Unit
$R_{thj-case}$	Thermal Resistance Junction-Case Max	1 °C/W

**Table 5: Electrical Characteristics ( $T_{case} = 25\text{ °C}$  unless otherwise specified)**

Symbol	Parameter	Test Conditions	Min.	Typ.	Max.	Unit
$I_{CS(SS)}$	Collector-Source Current ( $V_{BS} = V_{GS} = 0\text{ V}$ )	$V_{CS(SS)} = 1700\text{ V}$			100	$\mu\text{A}$
$I_{BS(OS)}$	Base-Source Current ( $I_C = 0, V_{GS} = 0\text{ V}$ )	$V_{BS(OS)} = 30\text{ V}$			10	$\mu\text{A}$
$I_{SB(OS)}$	Source-Base Current ( $I_C = 0, V_{GS} = 0\text{ V}$ )	$V_{SB(OS)} = 9\text{ V}$			100	$\mu\text{A}$
$I_{GS(OS)}$	Gate-Source Leakage	$V_{GS} = \pm 20\text{ V}$			500	nA
$V_{CS(ON)}$	Collector-Source ON Voltage	$V_{GS} = 10\text{ V } I_C = 1.8\text{ A } I_B = 0.36\text{ A}$ $V_{GS} = 10\text{ V } I_C = 0.7\text{ A } I_B = 70\text{ mA}$		1 1	1.5 1.3	V V
$h_{FE}$	DC Current Gain	$I_C = 1.8\text{ A } V_{CS} = 1\text{ V } V_{GS} = 10\text{ V}$ $I_C = 0.7\text{ A } V_{CS} = 1\text{ V } V_{GS} = 10\text{ V}$	3.5 6	5 10		
$V_{BS(ON)}$	Base-Source ON Voltage	$V_{GS} = 10\text{ V } I_C = 1.8\text{ A } I_B = 0.36\text{ A}$ $V_{GS} = 10\text{ V } I_C = 0.7\text{ A } I_B = 70\text{ mA}$		1 0.8	1.2 1	V V
$V_{GS(th)}$	Gate Threshold Voltage	$V_{BS} = V_{GS} I_B = 250\text{ }\mu\text{A}$	1.5	2.2	3	V
$C_{iss}$	Input Capacitance	$V_{CS} = 25\text{ V } f = 1\text{ MHz}$ $V_{GS} = V_{CB} = 0$		750		pF
$Q_{GS(tot)}$	Gate-Source Charge	$V_{CS} = 15\text{ V } V_{GS} = 10\text{ V}$ $V_{CB} = 0 I_C = 1.8\text{ A}$		12.5		nC
$t_s$	INDUCTIVE LOAD Storage Time	$V_{GS} = 10\text{ V}$ $R_G = 47\text{ }\Omega V_{Clamp} = 1200\text{ V}$		760		ns
$t_f$	Fall Time	$t_p = 4\text{ }\mu\text{s } I_C = 1.8\text{ A } I_B = 0.36\text{ A}$		14		ns

Symbol	Parameter	Test Conditions	Min.	Typ.	Max.	Unit
$t_s$ $t_f$	INDUCTIVE LOAD Storage Time Fall Time	$V_{GS} = 10\text{ V}$ $R_G = 47\ \Omega$ $t_p = 4\ \mu\text{s}$ $V_{Clamp} = 1200\text{ V}$ $I_C = 0.7\text{ A}$ $I_B = 70\text{ mA}$		690 32		ns ns
$V_{CSW}$	Maximum Collector-Source Voltage without Snubber	$R_G = 47\ \Omega$ $h_{FE} = 5\text{ A}$ $I_C = 3\text{ A}$	1500			V
$V_{CS(dyn)}$	Collector-Source Dynamic Voltage (500 ns)	$V_{CC} = V_{Clamp} = 400\text{ V}$ $R_G = 47\ \Omega$ $I_B = 0.1\text{ A}$ $t_{peak} = 500\text{ ns}$ $V_{GS} = 10\text{ V}$ $I_C = 0.5\text{ A}$ $I_{Bpeak} = 1\text{ A}$		3.9		V
$V_{CS(dyn)}$	Collector-Source Dynamic Voltage (1 $\mu\text{s}$ )	$V_{CC} = V_{Clamp} = 400\text{ V}$ $R_G = 47\ \Omega$ $I_B = 0.1\text{ A}$ $t_{peak} = 500\text{ ns}$ $V_{GS} = 10\text{ V}$ $I_C = 0.5\text{ A}$ $I_{Bpeak} = 1\text{ A}$		2.2		V

Figure 3: Safe Operating Area

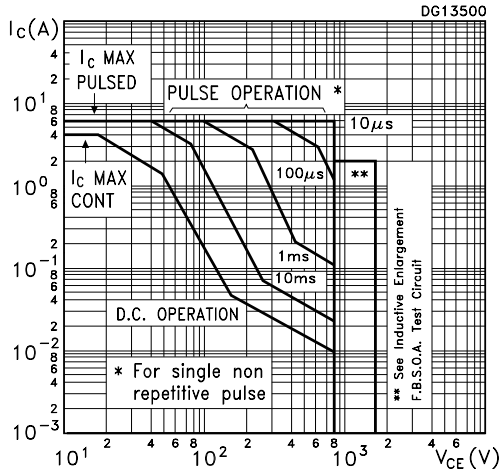

Figure 4: Reverse Biased Safe Operating Area

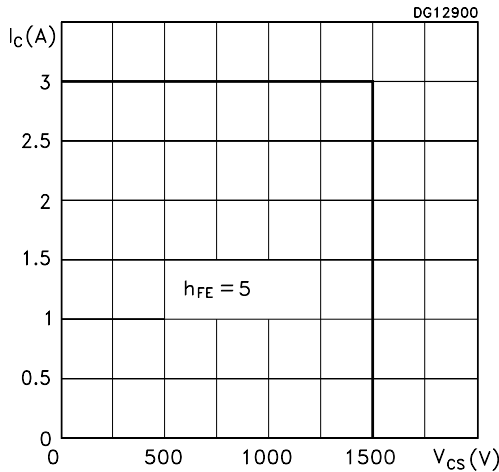

Figure 5: DC Current Gain

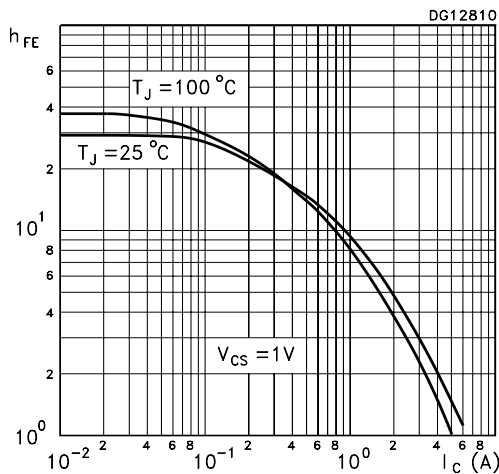

Figure 6: Output Characteristics

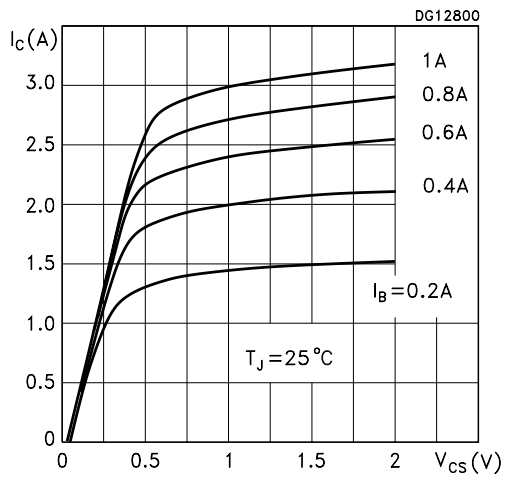

Figure 7: Gate Threshold Voltage vs Temperature

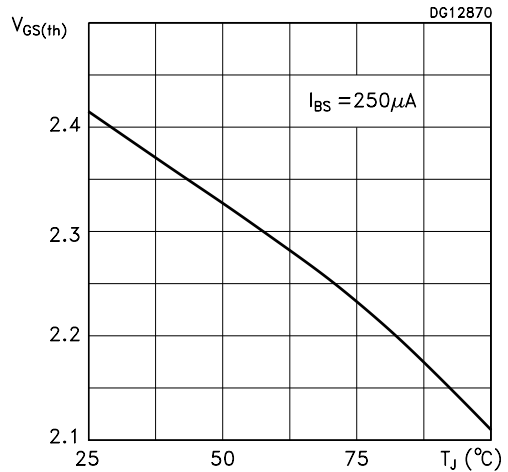

Figure 8: DC Current Gain

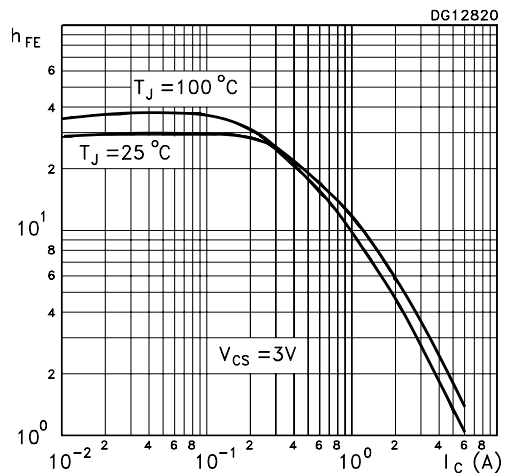

Figure 9: Collector-Source On Voltage

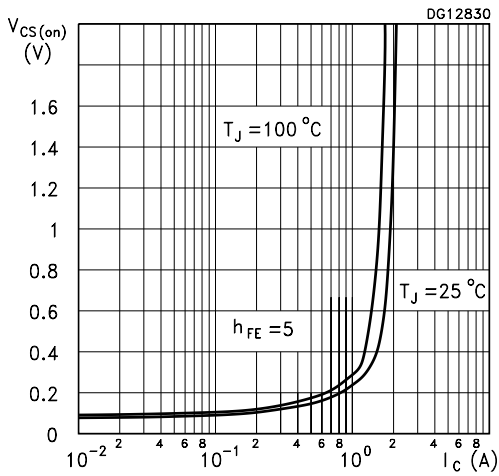

Figure 10: Base-Source On Voltage

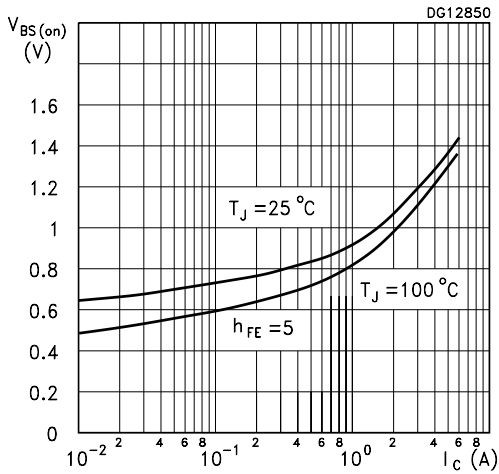

Figure 11: Inductive Load Switching Time

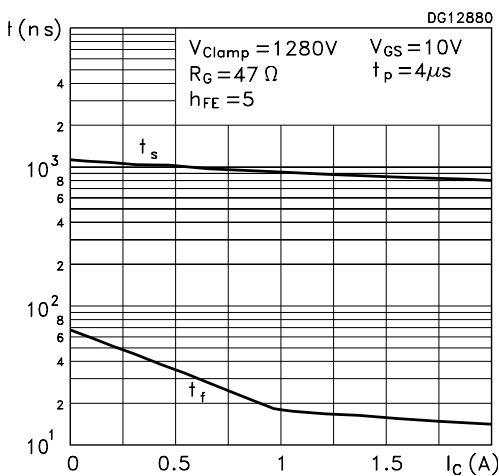

Figure 12: Collector-Source On Voltage

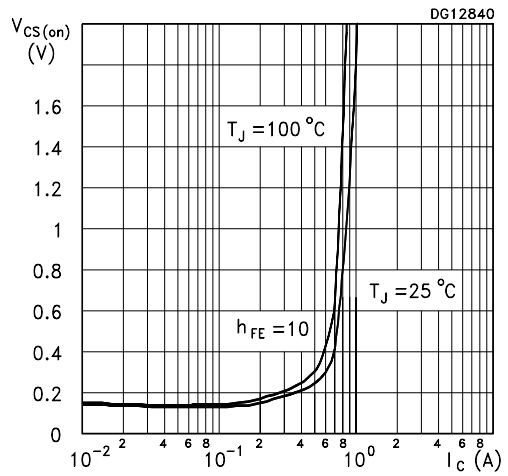

Figure 13: Base-Source On Voltage

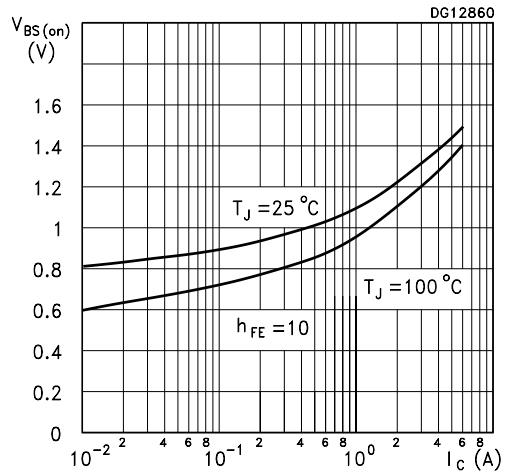

Figure 14: Inductive Load Switching Time

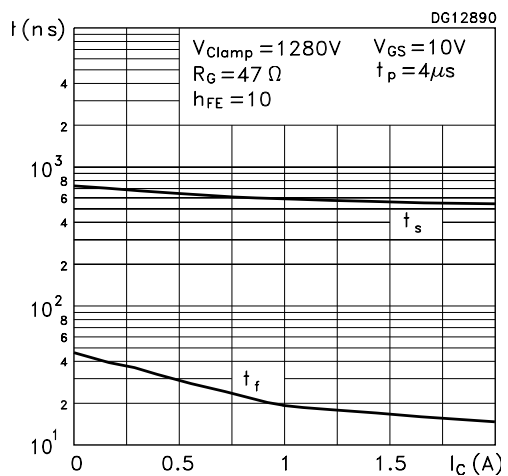

Figure 15: Dynamic Collector-Emitter Saturation Voltage

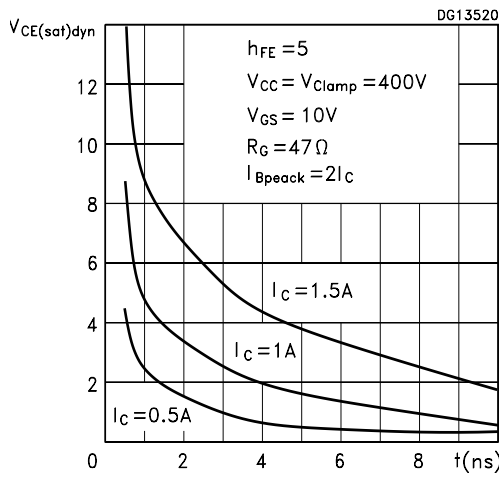

Figure 16: Inductive Load Enlargement FBSOA Circuit

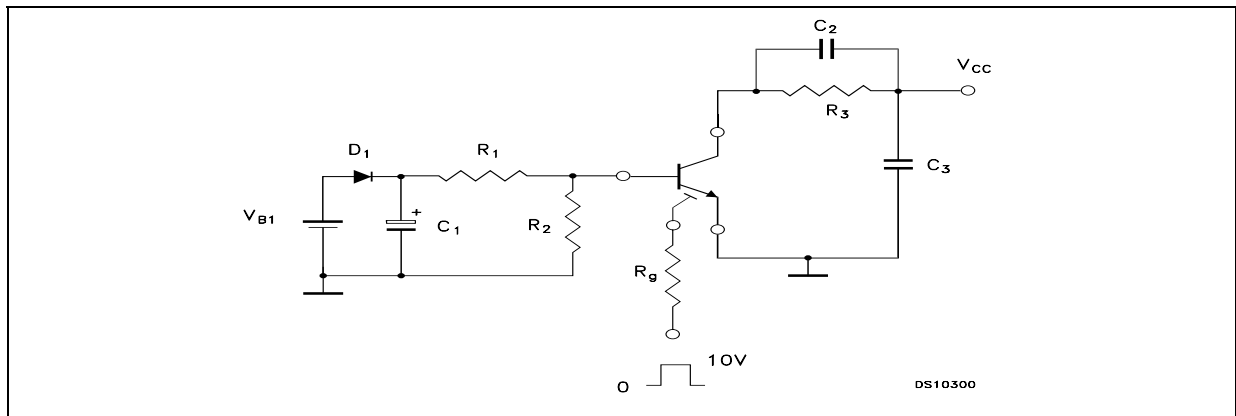
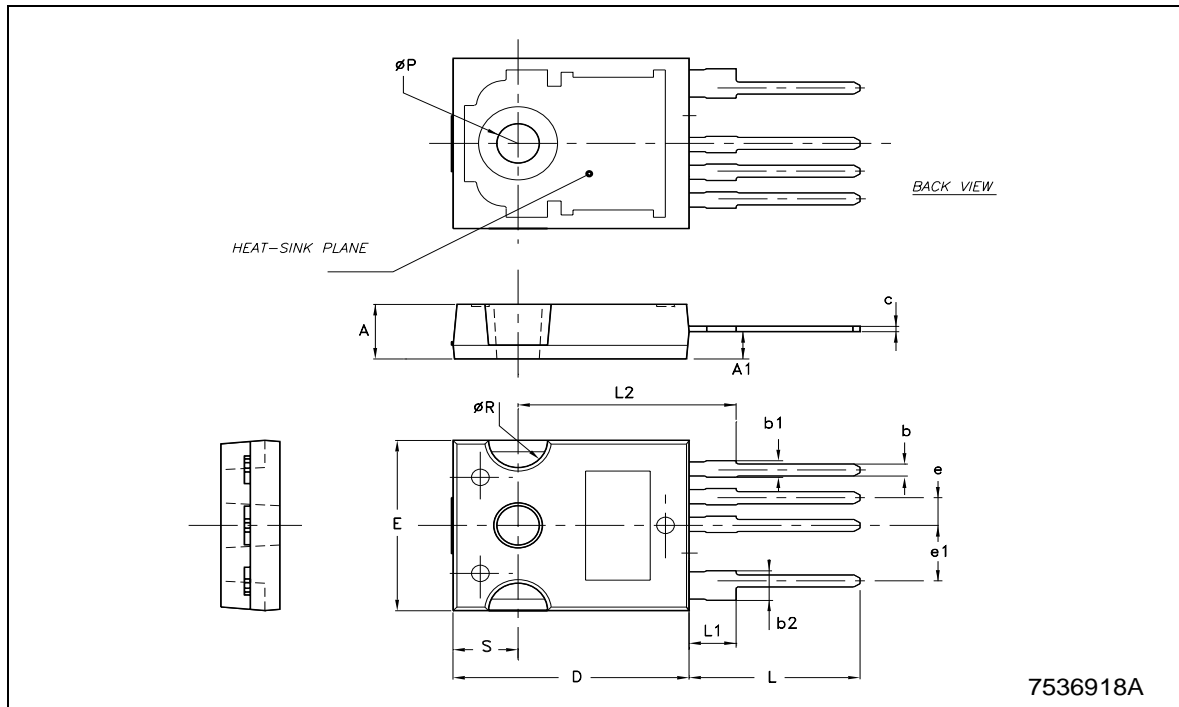

Table 6: Components, Values

$V_{B1} = 4.16 V$	$C_1 = 220 nF$
$D_1 = BA157$	$C_2 \leq 70 pF$
$R_1 = 1 \Omega$	$C_3 = 50 nF$
$R_2 = 100 \Omega$	$V_g = 10 V$
$R_3 = V_{CC} / I_{Cn}$	Pulse Time = $5 \mu s$
$R_g = 47 \Omega$	

## TO247-4L MECHANICAL DATA

DIM.	mm		
	MIN.	TYP.	MAX.
A	4.85		5.15
A1	2.20		2.60
b	0.95	1.10	1.30
b1	1.30		1.70
b2	2.50		2.90
c	0.40		0.80
D	19.85		20.15
E	15.45		15.75
e		2.54	
e1		5.08	
L	14.20		14.80
L1	3.70		4.30
L2		18.50	
ØP	3.55		3.65
ØR	4.50		5.50
S		5.50	



**Table 7: Revision History**

<b>Version</b>	<b>Release Date</b>	<b>Change Designator</b>
13-Sep-2004	1	First Release.



Information furnished is believed to be accurate and reliable. However, STMicroelectronics assumes no responsibility for the consequences of use of such information nor for any infringement of patents or other rights of third parties which may result from its use. No license is granted by implication or otherwise under any patent or patent rights of STMicroelectronics. Specification mentioned in this publication are subject to change without notice. This publication supersedes and replaces all information previously supplied. STMicroelectronics products are not authorized for use as critical components in life support devices or systems without express written approval of STMicroelectronics.

The ST logo is a registered trademark of STMicroelectronics.  
All other names are the property of their respective owners.

© 2004 STMicroelectronics – All Rights reserved

STMicroelectronics group of companies

Australia - Belgium - Brazil - Canada - China - Czech Republic - Finland - France - Germany - Hong Kong - India - Israel - Italy - Japan -  
Malaysia - Malta - Morocco - Singapore - Spain - Sweden - Switzerland - United Kingdom - United States of America.

[www.st.com](http://www.st.com)